

Mini Coax cable assemblies and accessories

Page

Mini Coax cable assemblies – general information	08.02
Assemblies with standard and low-profile modules	08.03
Assemblies with single-row modules and with heavy duty hoods/housings . . .	08.04
Accessories	08.05

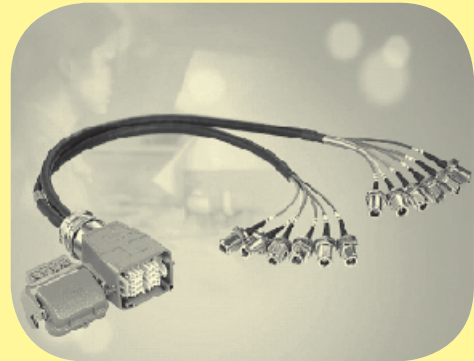
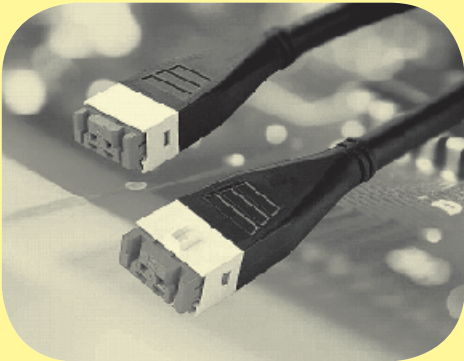
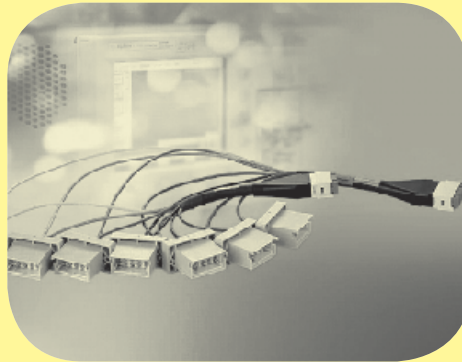

The Mini Coax product range also includes various cable assemblies and accessories, which provide customers with flexible application options.

The Mini Coax cable connector is available as plug and socket and is crimped to a coaxial cable that can be individually assembled with RF-cable connectors (SMA, SMB, N-type ...). While delivering high RF transmission performance, the moulded Mini Coax cable assemblies provide robust connections. The various angle mould types meet different cable routing requirements according to the available space.

Thanks to various accessories, such as backplane frame, Han® housing insert and press-in cable housing ..., customized connecting requirements can be met.

Remark:

The cable assemblies and accessories shown are part of the overall product range.

Additional, customized parts are available on request.

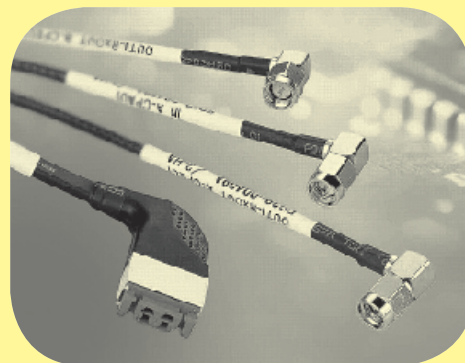

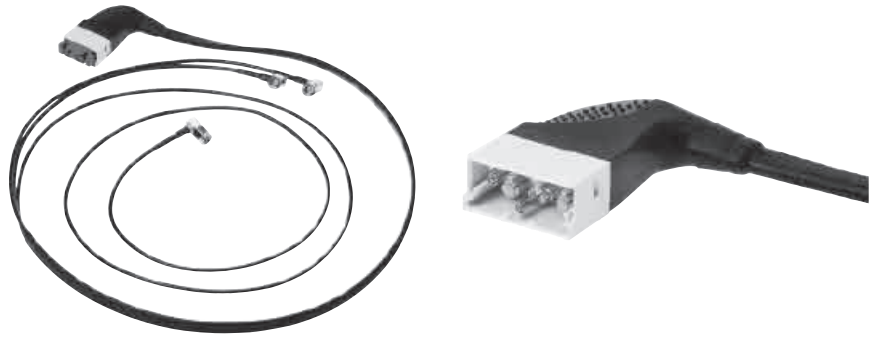

Cable assemblies

Identification	Number of contacts	Part No.	Drawing	Dimensions [mm]
Cable assembly for mating with the angled standard module	1-10	on request		
Cable assembly for mating with the angled low-profile module	1-6	on request		

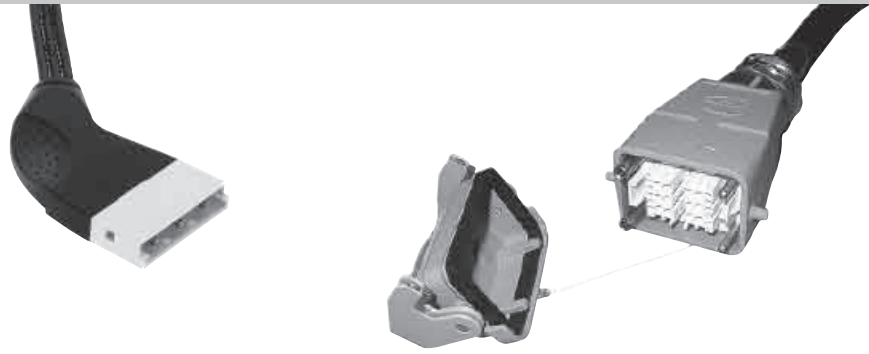

Cable assemblies

Identification	Number of contacts	Part No.	Drawing	Dimensions [mm]
----------------	--------------------	----------	---------	-----------------

Cable assembly for mating with the angled single-row module

1-3

on request

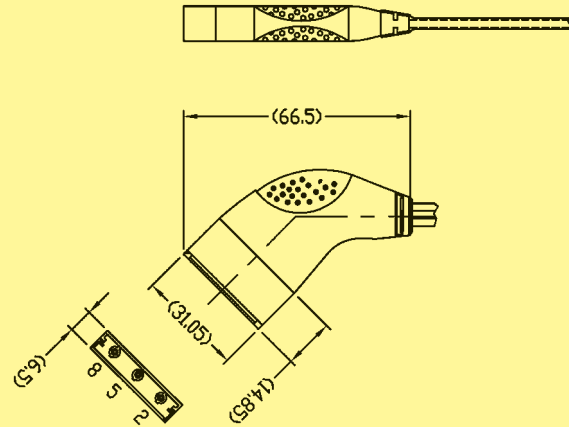

Cable assembly with heavy duty hoods/housings

1-10

on request

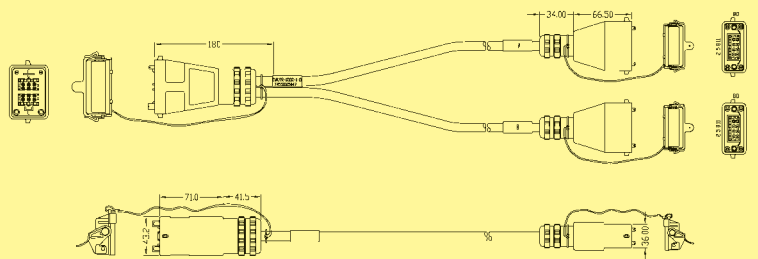

Mini Coax
Cables



Accessories

Identification

Part No.

Backplane frame

07 71 100 0042

Dimensions [mm]

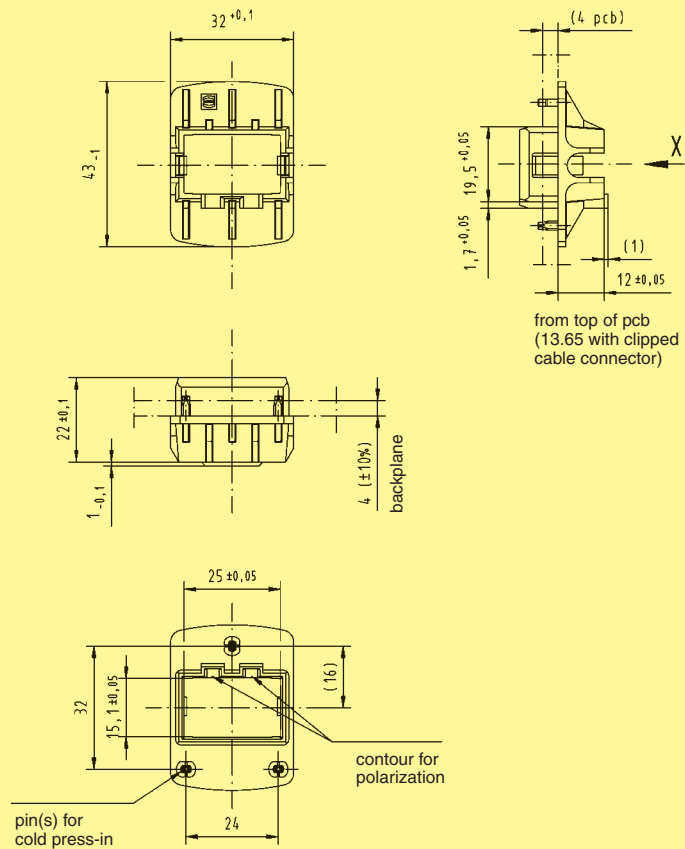

Board drillings

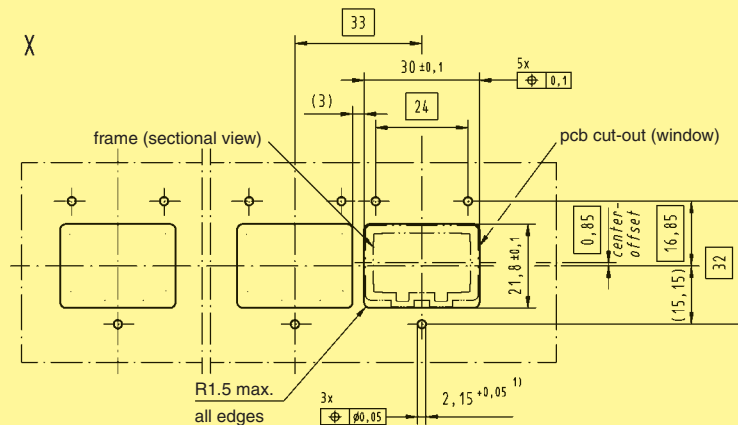

1) Non-metallized drillings

