

## Introduction

For the user, HARTING's novel and innovative solutions open up new, more convenient and extensive options for configuring Unmanaged Ethernet Switches. The solutions available to date offered only very limited or basic options for making alterations to different settings on an Ethernet Switch.

The user made changes to the settings or the configuration via the DIP switches on the Ethernet Switch. The extensive possibilities for applications were physically restricted by the enormous space requirements of the mechanical solution.

Now for the first time, HARTING's sCon solution makes it possible for the user to realise more configurations than have been possible to date.

Ease of handling and simple operation have been designed in to meet real-life application requirements. Simple and fast configuration is what this solution aims to achieve.

All sCon Ethernet Switches can be configured via a USB connection cable.

At first sight, sCon Ethernet Switches do not differ from the Ethernet Switches available to date. However, the possibilities that sCon has to offer become more than apparent to the user when he connects the Ethernet Switch via the front-side USB socket to a PC, laptop or hand-held PC.

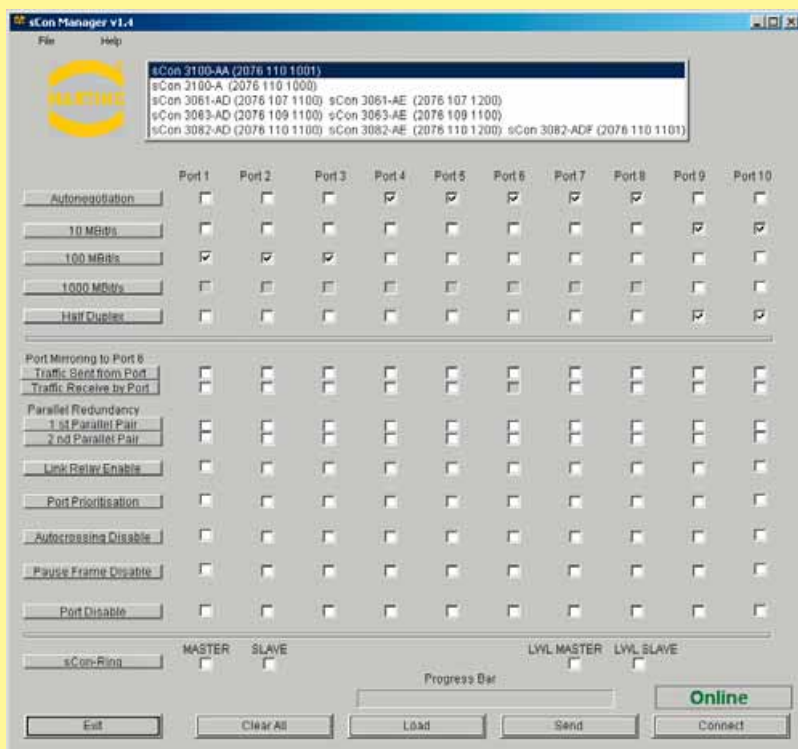

Figure 1 The Start-up menu

Once the sCon Ethernet Switch has been connected to a PC, it can be accessed on-screen in much the same manner as a commercially available USB stick (Figure 1: The Start-up menu).

The user only has to copy the sCon software in advance onto the PC. No administrator rights are required. The Ethernet Switch does not have to be connected to a power supply for configuration purposes. That means that the configuration procedure can take place at the user's location of choice:

in the office, workshop or production facility. The sCon Ethernet Switch automatically detects which power supply is connected: mains supply or power supply via the USB port. Please note that it is not possible to operate the Ethernet Switch purely via the USB port. For normal industrial operations, the power must be supplied via one of the redundant inputs.

## Introduction

Making configuration settings by means of DIP switches may appear to be uncomplicated. However, accidentally making an alteration to the configuration can happen more quickly than one would think possible, and in so doing make considerable changes to the previously set procedures. The sCon family prevents these inadvertent alterations to the configuration. No alteration can be made to the configuration without an USB connection and the software.

Each configuration can be archived and the backups retrieved for future projects. By making backups of the configuration, all settings can be conveniently stored in case servicing is necessary.

Archived configurations can be imported and printed out when convenient. These extensive options in sCon ensure that data security enjoys the significance it deserves.

The switch configuration is transmitted only when a new configuration is uploaded via the corresponding 'Send' button. This means that until the data has actually been uploaded, it is still possible to read-in the 'old' data from the sCon Ethernet Switch via the Refresh option. This means it is easily possible to reverse any inadvertent activation in the corresponding menu.

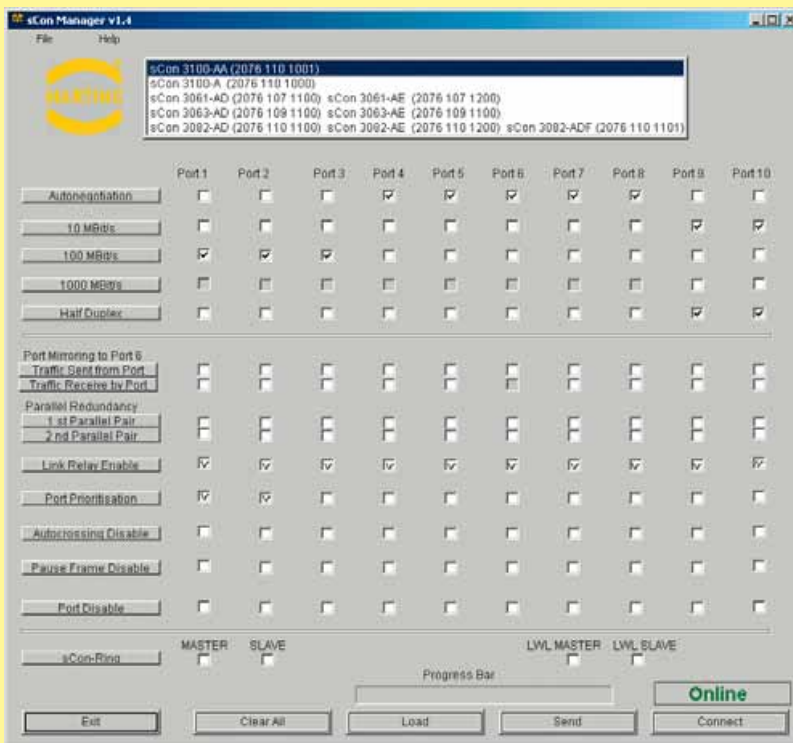

Figure 2 Example of a configuration

Once configured, the Ethernet Switch can be utilised immediately. The configuration remains stored in the Ethernet Switch after the USB cable is removed.

Meeting international standards, the USB port described is recognised as state-of-the-art technology. The standardised possibility for worldwide utilisation with all notebooks, PCs and Palmtops (revisions 1.0, 1.1 and 2.0) mean that this technology is suitable for universal usage.

The intuitive, but extensive options setting via the relevant buttons and the various options offered by sCon extend the range of applications for Unmanaged Ethernet Switches. With sCon, the gap between Unmanaged and manageable switches is getting smaller.

It is true that sCon is a solution for Unmanaged Ethernet Switches; however, it comes very close to Managed Ethernet Switch functionality.



## Ethernet Switch HARTING sCon 3000

Ethernet Switch family, unmanaged,  
for mounting onto top-hat mounting rail  
in control cabinets including sCon functions

### General Description

The Fast Ethernet Switches of the product family HARTING sCon 3000 can be configured via a USB port for special or more performance-oriented industrial usages. There are almost no limits to the different possibilities.

Activation of parallel and / or ring redundancy or port prioritisation will clearly increase the availability and reliability of data communications through the sCon 3000.

### Features

- Ethernet Switch acc. to IEEE 802.3
- Store and Forward Switching Mode, non-blocking, unmanaged
- Auto-crossing, Auto-negotiation, Auto-polarity
- Diagnostic LEDs (Link status, Act, Power, Data transmission rate, Error)
- Following settings are available via USB port:
  - Alarm signalling contact
  - Auto-negotiation
  - 10/100/1000 Mbit/s
  - Full/Half Duplex
  - Ring and/or parallel redundancy
  - Port enable / disable
  - Port priority
  - Port mirroring
  - Pause Frame

### Advantages

- Individually configurable via USB port
- Metal housing
- EMC, temperature range and mechanical stability meet the toughest demands
- Ring and/or parallel redundancy

### Application fields

- Industrial automation
- Railway applications
- Power distribution systems
- Automotive industry
- Mechanical engineering

Technical characteristics

**Ethernet interface RJ45**

Number of ports	6x / 8x / 10x 10/100Base-T(X), 2x 10/100/1000Base-T(X)
Cable types according to IEEE 802.3	Shielded Twisted Pair (STP) or Unshielded Twisted Pair (UTP), Category 5
Data rate	10 Mbit/s, 100 Mbit/s or 1000 Mbit/s (RJ45)
Maximum cable length	100 m (Twisted Pair; with Category 5 cable acc. to DIN EN 50 173-1)
Termination	RJ45 (Twisted Pair)
Diagnostics (via LED)	<ul style="list-style-type: none"> <li>• Status Link – Green</li> <li>• Data transfer (Act) – Green flashing</li> <li>• Data transfer rate (Speed) – 1000 Mbit/s: Green 100 Mbit/s: Yellow 10 Mbit/s: OFF</li> </ul>
Topology	Line, Ring, Star or mixed

**Power supply**

Input voltage	24 V DC
Termination	5-pole screw terminal, pluggable for redundant power supply
Diagnostics (via LED)	Power supply

**Alarm signalling contact**

Change-over contact, potential-free, 24 V DC / 0.5 A  
3-pole pluggable screw contact

**Design features**

Housing material	Metal (powder coated)
Dimensions (W x H x D)	60 x 132 x 104 mm (incl. cap, without connectors)
Degree of protection acc. to DIN 60529 sCon xxxx-AE	IP 30 IP 20
Mounting	<ul style="list-style-type: none"> <li>• 35 mm top-hat rail acc. to EN 60715</li> <li>• Panel mounting, vertical assembly</li> </ul>
Weight	approx. 0.6 kg

**Environmental conditions**

Operating temperature	0 °C ... +70 °C / –40 °C ... +70 °C (sCon 3100-AA only)
Storage temperature	–40 °C ... +85 °C
Relative humidity	10 % ... 95 % (non-condensing)

## Technical characteristics - F.O. termination

### Ethernet interface – F.O.

Number of ports	1x / 2x / 3x 100Base-FX
Cable types according to IEEE 802.3	<ul style="list-style-type: none"> <li>• Multimode fibre, 1300 nm; 50 / 125 µm or 62.5 / 125 µm</li> <li>• Singlemode fibre, 1300 nm; 9 µm (AF versions only)</li> </ul>
Data rate	100 Mbit/s
Maximum cable length	<ul style="list-style-type: none"> <li>• 2000 m (Multimode)</li> <li>• 15 km (Singlemode)</li> </ul>
Termination	SC-D female / ST female
Diagnostics (via LED)	<ul style="list-style-type: none"> <li>• Status Link – Green</li> <li>• Data transfer (Act) – Green flashing</li> </ul>
Wavelength	1300 nm
Transceive power T(X) max. (dynamic)	<ul style="list-style-type: none"> <li>• -14 dBm (50 / 125 µm)</li> <li>• -14 dBm (62.5 / 125 µm)</li> </ul>
Transmission power T(X) min.	<ul style="list-style-type: none"> <li>• -23.5 dBm (50 / 125 µm)</li> <li>• -20 dBm (62.5 / 125 µm)</li> </ul>
Receive power RX typical (dynamic)	<ul style="list-style-type: none"> <li>• -33.9 dBm (window)</li> <li>• -35.2 dBm (centre)</li> </ul>
Receive power RX max. (dynamic)	-14 dBm
Signal detection (dynamic)	-33 dBm
Topology	Line, Ring, Star or mixed



## Ethernet Switch HARTING sCon 3100-A

10-port Ethernet Switch for mounting onto top-hat mounting rail  
in control cabinets including sCon functions

Unmanaged	IP 30	PROFINET compatible <input checked="" type="checkbox"/>	EtherNet/IP compatible <input type="checkbox"/>
-----------	-------	---	---

Number of ports, Copper / Termination	10x 10/100Base-T(X) / RJ45 (Twisted Pair)
Input voltage / Termination	24 V DC / 5-pole screw terminal, pluggable redundant power supply
Permissible range (min/max)	9.6 V ... 36 V DC
Input current	approx. 170 mA (at 24 V DC)
Alarm signalling contact	Change-over contact, potential-free, 24 V DC / 0.5 A 3-pole pluggable screw contact
Housing material	Metal (powder coated)
Dimensions (W x H x D)	60 x 132 x 104 mm (incl. cap, without connectors)
Weight	approx. 0.6 kg
Operating temperature	0 °C ... +70 °C
Approvals	UL 508; UL 60 950-1
MTBF	745 000 h

Identification	Part number	Drawing	Dimensions in mm
----------------	-------------	---------	------------------

**HARTING sCon 3100-A**  
Ethernet Switch  
with 10 RJ45 ports  
including  
Set for assembly on standard rail

20 76 110 1000

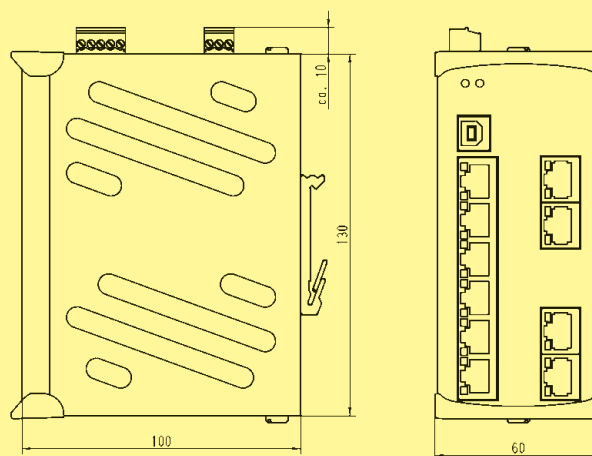



## Ethernet Switch HARTING sCon 3100-AA

10-port Ethernet Switch for mounting onto top-hat mounting rail in control cabinets including 2 Gigabit ports and sCon functions extended temperature range

Unmanaged	IP 30	PROFINET compatible <input checked="" type="checkbox"/>	EtherNet/IP compatible <input type="checkbox"/>
-----------	-------	---	---

Number of ports, Copper / Termination	8x 10/100Base-T(X) / RJ45 (Twisted Pair) 2x 10/100/1000Base-T(X) / RJ45 (Twisted Pair)
Input voltage / Termination	24 / 48 V DC / 5-pole screw terminal, pluggable redundant power supply
Permissible range (min/max)	9.6 V ... 60 V DC
Input current	approx. 240 mA (at 24 V DC)
Alarm signalling contact	Change-over contact, potential-free, 24 V DC / 0.5 A 3-pole pluggable screw contact
Housing material	Metal (powder coated)
Dimensions (W x H x D)	60 x 132 x 104 mm (incl. cap, without connectors)
Weight	approx. 0.6 kg
Operating temperature	-40 °C ... +70 °C
Approvals	UL 508; UL 60 950-1
MTBF	670 000 h

sCon 3000

Identification	Part number	Drawing	Dimensions in mm
----------------	-------------	---------	------------------

### HARTING sCon 3100-AA

Ethernet Switch  
with 10 RJ45 ports  
including  
Set for assembly on standard rail

20 76 110 1001

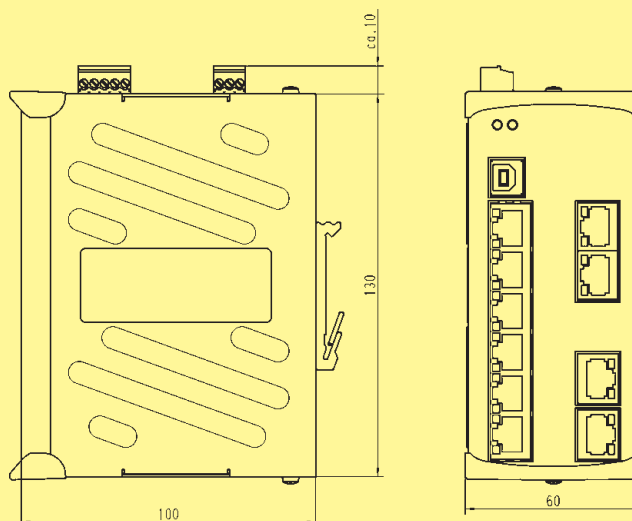



## Ethernet Switch HARTING sCon 3061-AD

7-port Ethernet Switch for mounting onto top-hat mounting rail  
in control cabinets including 1 F.O. port (SC, MM) and sCon functions

Unmanaged	IP 30	PROFINET compatible <input checked="" type="checkbox"/>	EtherNet/IP compatible <input type="checkbox"/>
-----------	-------	---	---

Number of ports, Copper / Termination	6x 10/100Base-T(X) / RJ45 (Twisted Pair)
Number of ports, F.O. / Termination	1x 100Base-FX / SC-D female
Input voltage / Termination	24 V DC / 5-pole screw terminal, pluggable redundant power supply
Permissible range (min/max)	9.6 V ... 36 V DC
Input current	approx. 240 mA (at 24 V DC)
Alarm signalling contact	Change-over contact, potential-free, 24 V DC / 0.5 A 3-pole pluggable screw contact
Housing material	Metal (powder coated)
Dimensions (W x H x D)	60 x 132 x 104 mm (incl. cap, without connectors)
Weight	approx. 0.6 kg
Operating temperature	0 °C ... +70 °C
Approvals	UL 508; UL 60 950-1
MTBF	660 000 h

Identification	Part number	Drawing	Dimensions in mm
----------------	-------------	---------	------------------

**HARTING sCon 3061-AD**  
Ethernet Switch  
6 RJ45 ports  
1 SC port  
including  
Set for assembly on standard rail

20 76 107 1100

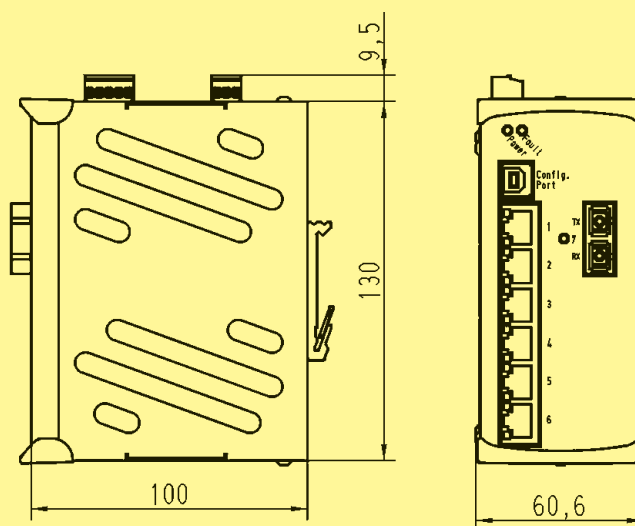



## Ethernet Switch HARTING sCon 3063-AD

9-port Ethernet Switch for mounting onto top-hat mounting rail  
in control cabinets including 3 F.O. ports (SC, MM) and sCon functions

Unmanaged	IP 30	PROFINET compatible <input checked="" type="checkbox"/>	EtherNet/IP compatible <input type="checkbox"/>
-----------	-------	---	---

Number of ports, Copper / Termination	6x 10/100Base-T(X) / RJ45 (Twisted Pair)
Number of ports, F.O. / Termination	3x 100Base-FX / SC-D female
Input voltage / Termination	24 V DC / 5-pole screw terminal, pluggable redundant power supply
Permissible range (min/max)	9.6 V ... 36 V DC
Input current	approx. 290 mA (at 24 V DC)
Alarm signalling contact	Change-over contact, potential-free, 24 V DC / 0.5 A 3-pole pluggable screw contact
Housing material	Metal (powder coated)
Dimensions (W x H x D)	60 x 132 x 104 mm (incl. cap, without connectors)
Weight	approx. 0.6 kg
Operating temperature	0 °C ... +70 °C
Approvals	UL 508; UL 60 950-1
MTBF	660 000 h

sCon 3000

Identification	Part number	Drawing	Dimensions in mm
----------------	-------------	---------	------------------

**HARTING sCon 3063-AD**  
Ethernet Switch  
6 RJ45 ports  
3 SC ports  
including  
Set for assembly on standard rail

20 76 109 1100

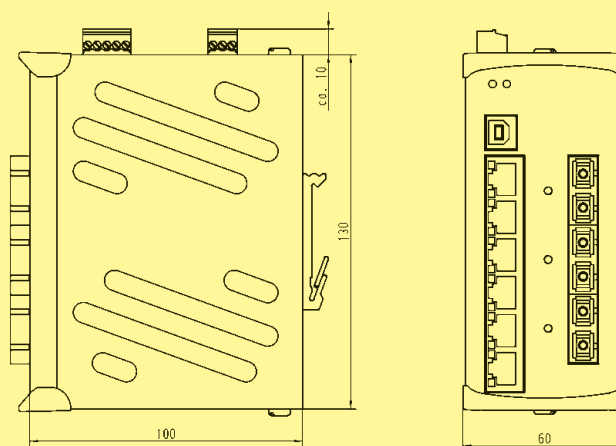



## Ethernet Switch HARTING sCon 3082-AD

10-port Ethernet Switch for mounting onto top-hat mounting rail  
in control cabinets including 2 F.O. ports (SC, MM) and sCon functions

Unmanaged	IP 30	PROFINET compatible <input checked="" type="checkbox"/>	EtherNet/IP compatible <input type="checkbox"/>
-----------	-------	---	---

Number of ports, Copper / Termination	8x 10/100Base-T(X) / RJ45 (Twisted Pair)
Number of ports, F.O. / Termination	2x 100Base-FX / SC-D female
Input voltage / Termination	24 V DC / 5-pole screw terminal, pluggable redundant power supply
Permissible range (min/max)	9.6 V ... 36 V DC
Input current	approx. 260 mA (at 24 V DC)
Alarm signalling contact	Change-over contact, potential-free, 24 V DC / 0.5 A 3-pole pluggable screw contact
Housing material	Metal (powder coated)
Dimensions (W x H x D)	60 x 132 x 104 mm (incl. cap, without connectors)
Weight	approx. 0.6 kg
Operating temperature	0 °C ... +70 °C
Approvals	UL 508; UL 60 950-1
MTBF	585 000 h

Identification	Part number	Drawing	Dimensions in mm
----------------	-------------	---------	------------------

**HARTING sCon 3082-AD**  
Ethernet Switch  
8 RJ45 ports  
2 SC ports  
including  
Set for assembly on standard rail

20 76 110 1100

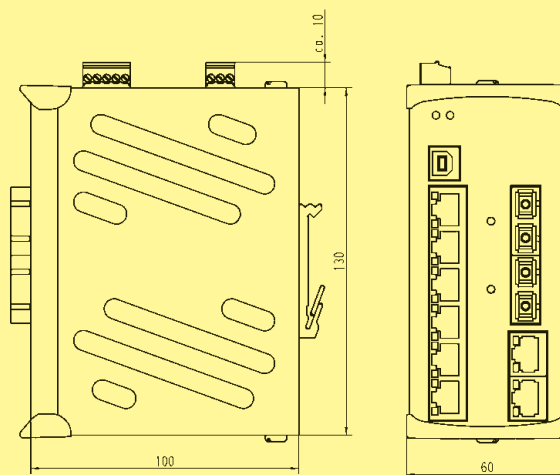



## Ethernet Switch HARTING sCon 3061-AE

7-port Ethernet Switch for mounting onto top-hat mounting rail  
in control cabinets including 1 F.O. port (ST, MM) and sCon functions

Unmanaged	IP 20	PROFINET compatible <input checked="" type="checkbox"/>	EtherNet/IP compatible <input type="checkbox"/>
-----------	-------	---	---

Number of ports, Copper / Termination	6x 10/100Base-T(X) / RJ45 (Twisted Pair)
Number of ports, F.O. / Termination	1x 100Base-FX / ST female
Input voltage / Termination	24 V DC / 5-pole screw terminal, pluggable redundant power supply
Permissible range (min/max)	9.6 V ... 36 V DC
Input current	approx. 240 mA (at 24 V DC)
Alarm signalling contact	Change-over contact, potential-free, 24 V DC / 0.5 A 3-pole pluggable screw contact
Housing material	Metal (powder coated)
Dimensions (W x H x D)	60 x 132 x 104 mm (incl. cap, without connectors)
Weight	approx. 0.6 kg
Operating temperature	0 °C ... +70 °C
Approvals	UL 508; UL 60 950-1
MTBF	660 000 h

sCon 3000

Identification	Part number	Drawing	Dimensions in mm
----------------	-------------	---------	------------------

**HARTING sCon 3061-AE**  
Ethernet Switch  
6 RJ45 ports  
1 ST port  
including  
Set for assembly on standard rail

20 76 107 1200

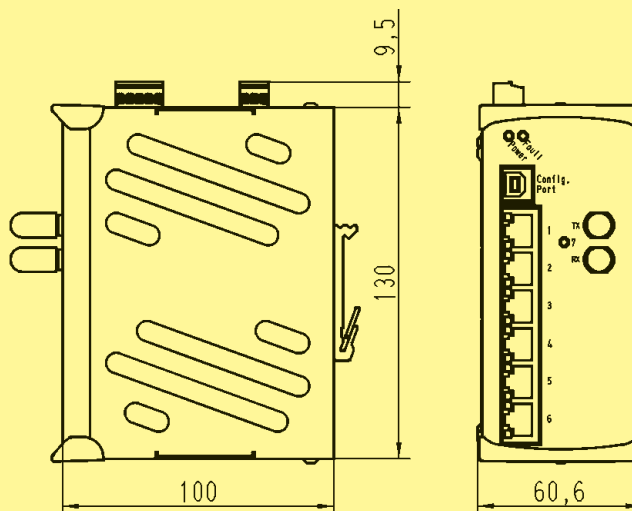



## Ethernet Switch HARTING sCon 3063-AE

9-port Ethernet Switch for mounting onto top-hat mounting rail  
in control cabinets including 3 F.O. ports (ST, MM) and sCon functions

Unmanaged	IP 20	PROFINET compatible <input checked="" type="checkbox"/>	EtherNet/IP compatible <input type="checkbox"/>
-----------	-------	---	---

Number of ports, Copper / Termination	6x 10/100Base-T(X) / RJ45 (Twisted Pair)
Number of ports, F.O. / Termination	3x 100Base-FX / ST female
Input voltage / Termination	24 V DC / 5-pole screw terminal, pluggable redundant power supply
Permissible range (min/max)	9.6 V ... 36 V DC
Input current	approx. 290 mA (at 24 V DC)
Alarm signalling contact	Change-over contact, potential-free, 24 V DC / 0.5 A 3-pole pluggable screw contact
Housing material	Metal (powder coated)
Dimensions (W x H x D)	60 x 132 x 104 mm (incl. cap, without connectors)
Weight	approx. 0.6 kg
Operating temperature	0 °C ... +70 °C
Approvals	UL 508; UL 60 950-1
MTBF	660 000 h

Identification	Part number	Drawing	Dimensions in mm
----------------	-------------	---------	------------------

**HARTING sCon 3063-AE**  
Ethernet Switch  
6 RJ45 ports  
3 ST ports  
including  
Set for assembly on standard rail

20 76 109 1200

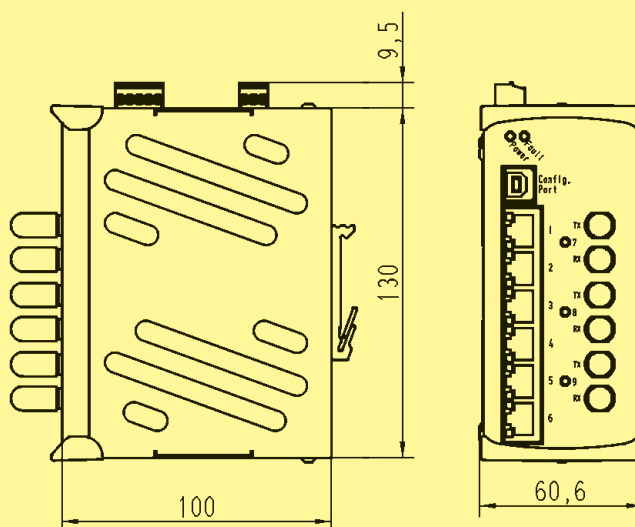



## Ethernet Switch HARTING sCon 3082-AE

10-port Ethernet Switch for mounting onto top-hat mounting rail  
in control cabinets including 2 F.O. ports (ST, MM) and sCon functions

Unmanaged	IP 20	PROFINET compatible <input checked="" type="checkbox"/>	EtherNet/IP compatible <input type="checkbox"/>
-----------	-------	---	---

Number of ports, Copper / Termination	8x 10/100Base-T(X) / RJ45 (Twisted Pair)
Number of ports, F.O. / Termination	2x 100Base-FX / ST female
Input voltage / Termination	24 V DC / 5-pole screw terminal, pluggable redundant power supply
Permissible range (min/max)	9.6 V ... 36 V DC
Input current	approx. 260 mA (at 24 V DC)
Alarm signalling contact	Change-over contact, potential-free, 24 V DC / 0.5 A 3-pole pluggable screw contact
Housing material	Metal (powder coated)
Dimensions (W x H x D)	60 x 132 x 104 mm (incl. cap, without connectors)
Weight	approx. 0.6 kg
Operating temperature	0 °C ... +70 °C
Approvals	UL 508; UL 60 950-1
MTBF	585 000 h

sCon 3000

Identification	Part number	Drawing	Dimensions in mm
----------------	-------------	---------	------------------

**HARTING sCon 3082-AE**  
Ethernet Switch  
8 RJ45 ports  
2 ST ports  
including  
Set for assembly on standard rail

20 76 110 1200

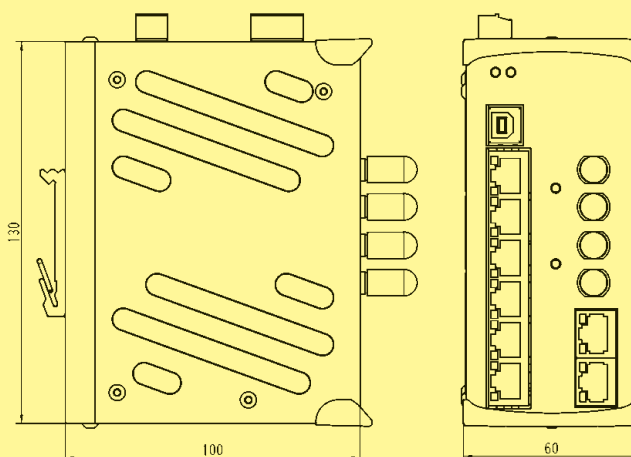



## Ethernet Switch HARTING sCon 3061-AF

7-port Ethernet Switch for mounting onto top-hat mounting rail  
in control cabinets including 1 F.O. port (SC, SM) and sCon functions

Unmanaged	IP 30	PROFINET compatible <input checked="" type="checkbox"/>	EtherNet/IP compatible <input type="checkbox"/>
-----------	-------	---	---

Number of ports, Copper / Termination	6x 10/100Base-T(X) / RJ45 (Twisted Pair)
Number of ports, F.O. / Termination	1x 100Base-FX / SC-D female (Singlemode)
Input voltage / Termination	24 V DC / 5-pole screw terminal, pluggable redundant power supply
Permissible range (min/max)	9.6 V ... 36 V DC
Input current	approx. 240 mA (at 24 V DC)
Alarm signalling contact	Change-over contact, potential-free, 24 V DC / 0.5 A 3-pole pluggable screw contact
Housing material	Metal (powder coated)
Dimensions (W x H x D)	60 x 132 x 104 mm (incl. cap, without connectors)
Weight	approx. 0.6 kg
Operating temperature	0 °C ... +70 °C
Approvals	cUL (in preparation)

Identification	Part number	Drawing	Dimensions in mm
----------------	-------------	---------	------------------

**HARTING sCon 3061-AF**  
Ethernet Switch  
6 RJ45 ports  
1 SC port  
including  
Set for assembly on standard rail

20 76 107 1102

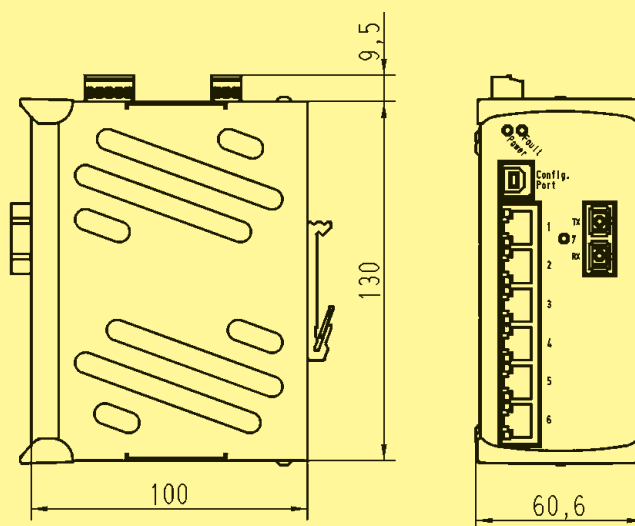



## Ethernet Switch HARTING sCon 3082-AF

10-port Ethernet Switch for mounting onto top-hat mounting rail  
in control cabinets including 2 F.O. ports (SC, SM) and sCon functions

Unmanaged	IP 30	PROFINET compatible <input checked="" type="checkbox"/>	EtherNet/IP compatible <input type="checkbox"/>
-----------	-------	---	---

Number of ports, Copper / Termination	8x 10/100Base-T(X) / RJ45 (Twisted Pair)
Number of ports, F.O. / Termination	2x 100Base-FX / SC-D female (Singlemode)
Input voltage / Termination	24 V DC / 5-pole screw terminal, pluggable redundant power supply
Permissible range (min/max)	9.6 V ... 36 V DC
Input current	approx. 260 mA (at 24 V DC)
Alarm signalling contact	Change-over contact, potential-free, 24 V DC / 0.5 A 3-pole pluggable screw contact
Housing material	Metal (powder coated)
Dimensions (W x H x D)	60 x 132 x 104 mm (incl. cap, without connectors)
Weight	approx. 0.6 kg
Operating temperature	0 °C ... +70 °C
Approvals	cUL (in preparation)

sCon 3000

Identification	Part number	Drawing	Dimensions in mm
----------------	-------------	---------	------------------

**HARTING sCon 3082-AF**  
Ethernet Switch  
8 RJ45 ports  
2 SC ports  
including  
Set for assembly on standard rail

20 76 110 1102

